

ISO-CARE™

Isolation Units

KENNEL

SOLUTIONS PTY LTD



The ISO-Care Advantage:

- Safely isolates infectious animals in an easy to clean unit
- Exhaust fan and drainage system reduces mess and odours
- Ships ready to use
- No special isolation rooms required

Ideal For Treating Parvo Virus!

A growing number of veterinary hospitals and animal shelters are choosing to ISO-Care for isolating animals due to contagious diseases or quarantine requirements. ISO-Care's innovative tempered glass design keeps all discharge within the unit—no more messy leaks! Plus, the attractive fibreglass interior washes clean in seconds. A two tiered drainage system keeps wastes and liquids away from animals, exiting through ISO-Care's floor drain, which can be connected to a sewer outlet.

Available in single or double deck configurations, ISO-Care units ship completely assembled ready for operation.



FRP Sani-Cage™

Stacked Cage Units



The Stacked Cage System of the Future

Not your average stacked caging system, our Sani-Cage features a moulded, solid-surface fibreglass cage body with individual built-in drains that makes clean up a snap. A raised polyethylene grid floor keeps animals away from liquids, while the sloped cage floor underneath routes all liquids to the hidden drain in the back corner.

Sani-Cages come with a form-welded stainless steel gate for years of trouble-free operation. Available in 914mm and 1219mm widths double-stacked, and 914mm width triple-stacked, Sani-Cage modular units can be configured for your exact caging needs. The units arrive completely assembled with internal plumbing already complete. Just route the final plumbing from the bottom of the units to your floor drain, and your Sani-Cages are ready to use!

The FRP Sani-Cage Advantage:

- Built-in drains simplifying cleaning.
- Molded fibreglass body looks warmer and more attractive than cold metal cages.
- Comes completely assembled.

Exclusive distributor throughout Asia Pacific for-



For more information:

Contact Kennel Solutions

T: 1800 251 766

E: info@kennelsolutions.com.au

www.kennelsolutions.com.au

©Copyright 2007
Kennel Solutions Pty Limited.
ABN 82 107 418 262

ISO-CARE™

UNIT DETAILS & OPTIONS

Features

- Fibreglass enclosure
- Elevated plasticol-coated mesh floor
- Aluminium framed tempered glass door
- Interior Light
- Exhaust Fan
- 63.5mm PVC drain outlet
- Aluminium Legs
- Ships completely assembled

Exterior Dimensions

Single Lower Unit:
768mm wide x 1165mm high x
930mm deep

Double Deck Unit
774mm wide x 2076mm high x
930mm deep

Options

- See doors & accessories Insert for details
- Blue ABS Plastic side panel
 - Removable Top Cover

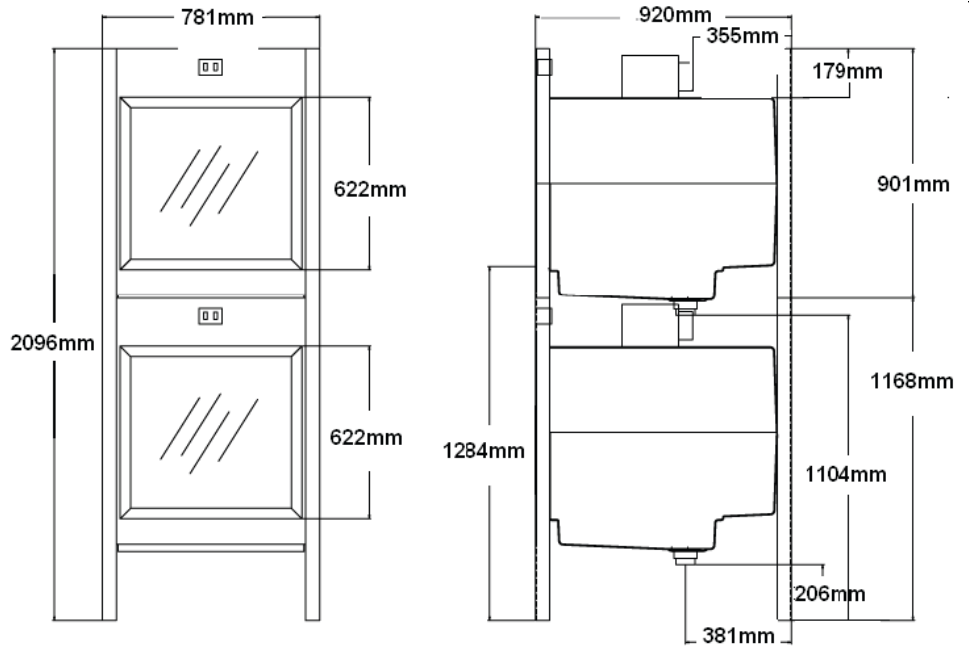

Front View

Side View

FRP Sani-Cage™

UNIT DETAILS & OPTIONS

Features

- Fibreglass Reinforced Plastic (FRP) units
- Built-in drains with 50mm PVC plumbing
- Aluminium Framework
- Stainless Steel formed-wire gate

Small Size
Side View

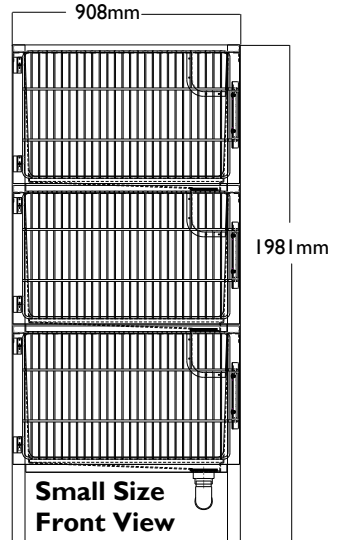
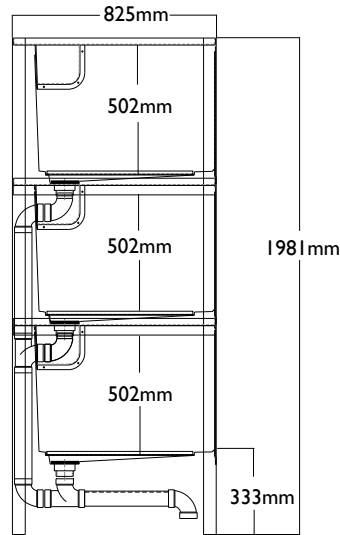

Small Size
Front View

Medium/large
Size Side View

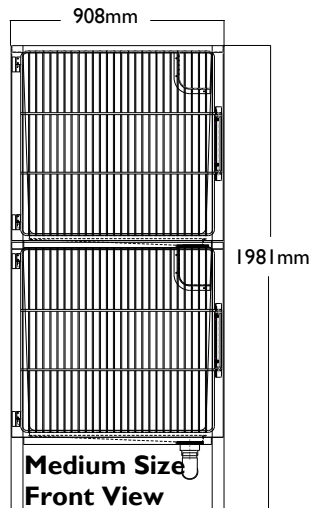
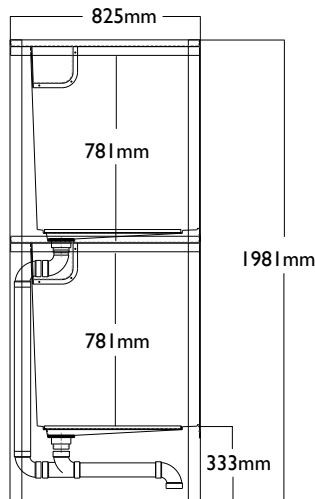

Medium Size
Front View

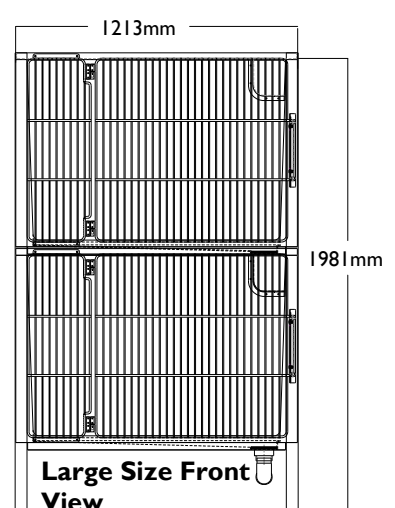

Large Size
Front View