

VSSI

Stainless Steel Cage



Installation Manual

VSSI, INC.

#1 Civil War Road - Area 5
P.O. Box 431
Carthage, MO 64836
1-800-299-9525
FAX 417-358-4716
email vssi@vssi.com
<http://www.vssi.com>

Product Warranty

VSSI warrants to the original purchaser only the following;

VSSI products carry a one year warranty unless otherwise expressed by VSSI literature. Stainless steel components in VSSI products are guaranteed to last a lifetime assuming they are used as intended, and properly maintained.

Items purchased by VSSI from other manufacturers and used as components or incorporated into VSSI equipment are covered by the respective manufacturers' warranties.

Warranties are void if it is determined by VSSI that the equipment was damaged or became defective due to abuse, weather, cleaning chemicals, accident, improper maintenance or alteration. Shipping costs to the factory will be the responsibility of the owner. The warranty covers all parts and labor to repair or replace defective product. Replacement or repair will be at VSSI's discretion.



#1 Civil War Road - Area 5
P.O. Box 431
Carthage, MO 64836
1-800-299-9525
FAX 417-358-4716
email vssi@vssi.com
<http://www.vssi.com>

Care & Cleaning

VSSI Stainless Steel Cages may be cleaned with any commercially available product recommended for use on stainless steel. Frequent cleaning will prolong the life and help maintain the natural luster of the stainless steel.

To prevent scratching, use a soft cloth to clean the cage surface. If scrubbing is necessary, use a nylon or plastic type scrubber. When cleaning, always rub in the direction of the “grain” of the metal.

To remove minor scratches, we recommend using a 3M ScotchBrite® scouring pad rubbed lightly in the direction of the “grain” of the metal.

Never use steel wool or steel brushes

When cleaning your cage, steel particles may become embedded into the stainless steel and cause rust.

Avoid use of chlorine bleach for cleaning.

Chlorides, bromides, iodides and thiocyanates are not acceptable cleaners for stainless steel products. They will cause pitting, corrosion and discoloration of the metal.

USE OF SUCH PRODUCTS WILL VOID WARRANTY ON ALL STAINLESS STEEL PRODUCTS.

Table of Contents

Pre-Installation.....	2
Parts Identification.....	3
Base Construction.....	4
Assembly.....	5-9
Optional Side Panel Installation.....	8
Top Panel Installation.....	9
Door/Latch Alignment.....	10
Back Strap Support Installation.....	11
Opt. Center Divider Installation.....	11
Care & Cleaning.....	12
Product Warranty.....	13



#1 Civil War Road - Area 5
P.O. Box 431
Carthage, MO 64836
1-800-299-9525
FAX 417-358-4716
email vssi@vssi.com
<http://www.vssi.com>

Pre-Installation

CLAIMS AGAINST SHIPMENT DAMAGE MUST BE MADE DIRECT TO VSSI WITHIN 7 DAYS OF RECEIPT OF MERCHANDISE.

Thank you for purchasing VSSI Stainless Steel Cages

Open packages carefully. Please inspect the shipping cartons and contents for any visible damage. This is important in the event that any breakage has occurred during transit.

Tools needed for assembly:

No. 3 Phillips
Screwdriver

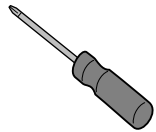

Level

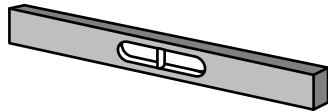

7/16"
Socket/Wrench



Framing
Square

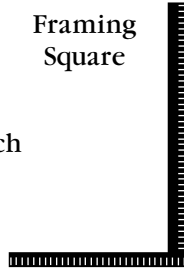

Leather Gloves Are Recommended



Back Strap Support Installation (caster bases only)

NOTE: DO NOT INSTALL BACK STRAPS UNTIL ALL CAGES ARE SQUARE AND DOORS HAVE BEEN ADJUSTED.

1. Two back support straps have been provided on all caster bank assemblies. These straps secure the back of the lower two rows of cages to the base.
2. Hook the strap to the base.
3. Expose the adhesive of the tape and press against the back side of cage assembly.
4. If you have a short bank of cages and the back straps protrude above the top of the cages, simply bend the strap back and over the top side of the cage bank.

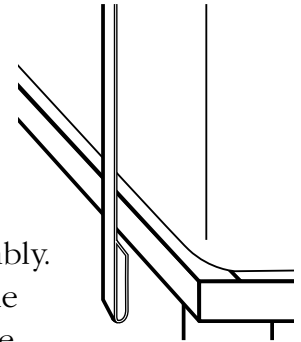

Optional Center Divider

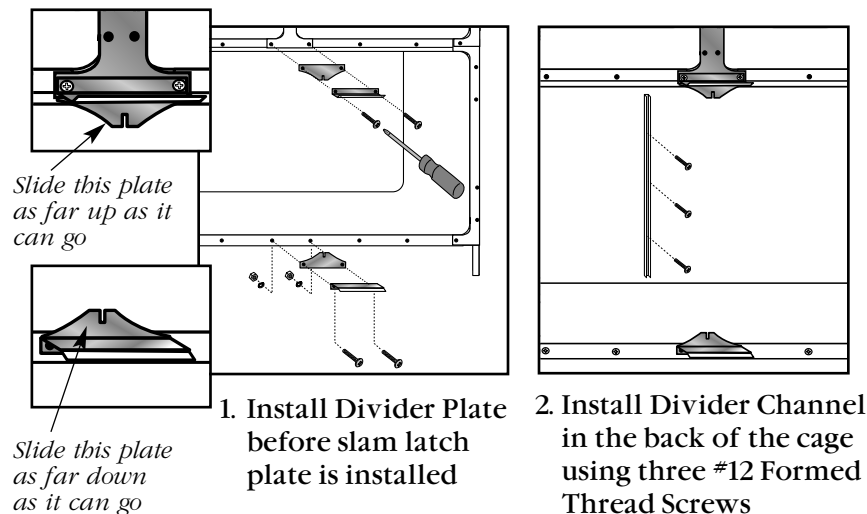

1. Install Divider Plate before slam latch plate is installed

2. Install Divider Channel in the back of the cage using three #12 Formed Thread Screws

Assembly Cont'd

- Use holes provide in side panels to string wire across the back of the cage bank. This will secure the back of the side panels.
- Hang all doors using hinge pins

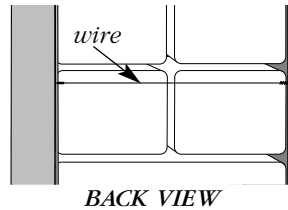

Door/Latch Alignment

- All cage doors should be centered over the cage opening. Hinge plate can be moved up and down to align the left side of the door.
- Once the left side of the door is aligned, the hinge plate can be moved left or right to align the right side of the door.

Firmly tighten screws

- Once door has been straightened, the latch may need adjusting so door will properly close. Adjust so the horizontal bar protruding from the cage door is centered inside the "V" shape of the latch. After it is centered, firmly tighten the screws.

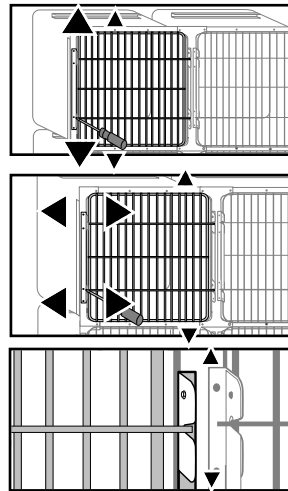

Double Door Alignment

- Follow the steps outlined previously to ensure the double doors are centered over the cage opening.
- Double door latch plate may need adjusted so doors will close properly. Simply loosen the two screws holding the top plate and slide it into place. Then tighten screws. Do the same on the bottom plate

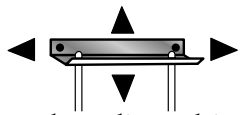
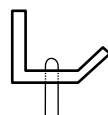
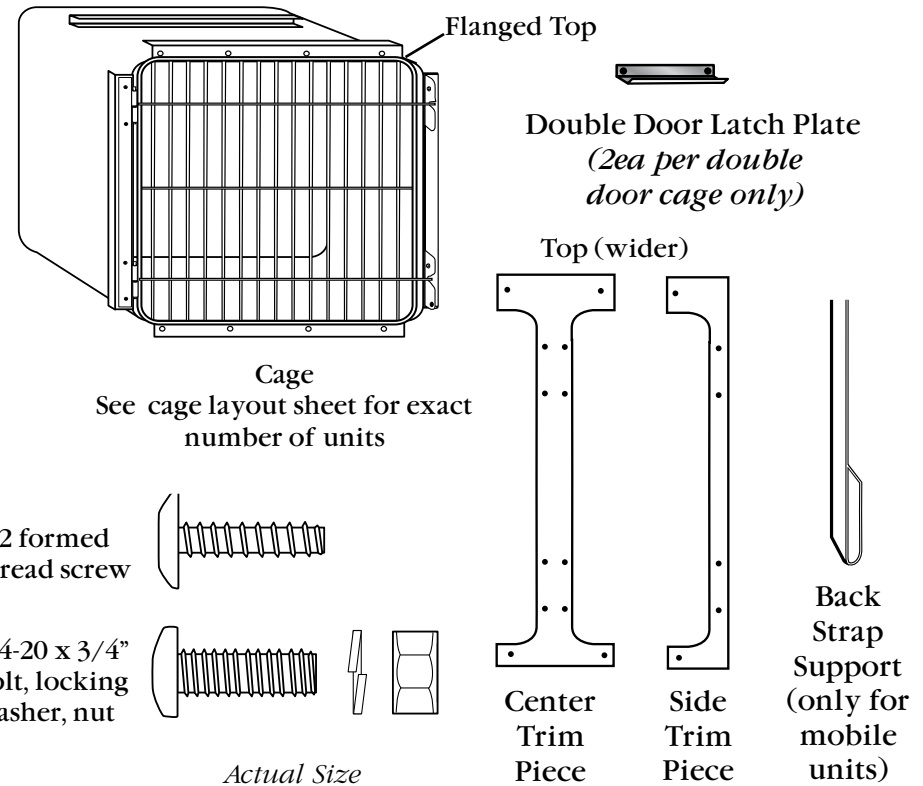

Plate can be adjusted in any direction to ensure proper alignment



Vertical latch rod should extend approx. 1/4" above plate and be centered inside the slot.

Parts Identification



Options & Accessories

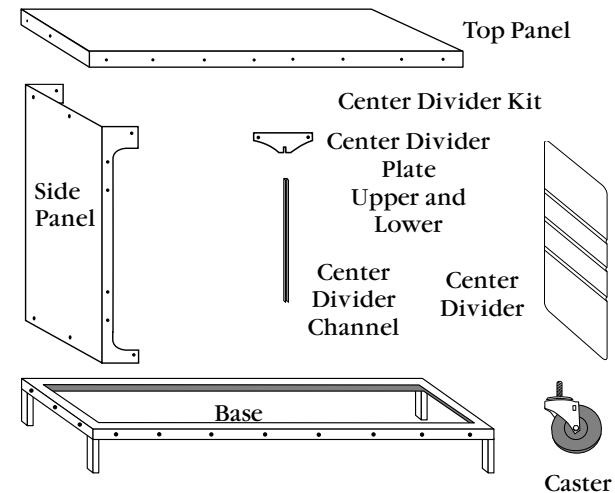

Base Construction

Metal Base:

Caster installation: Turn the base up side down and simply screw the caster stud into the threaded hole of the base leg.

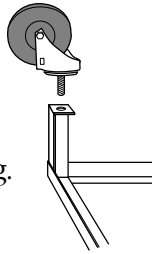

Multiple Unit Linking: If several bases have been ordered, they will need to be bolted together using 1/4-20 x 3/4" bolt, locking washer and nut to help insure stability.

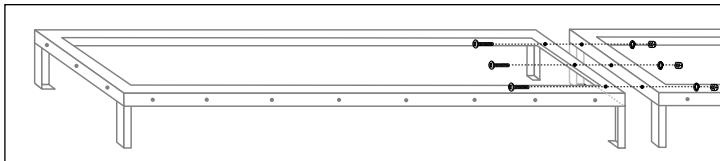

If a metal base option has not been ordered, a base will need to be constructed using one of the following two methods:

2" x 4" Construction: Use treated 2 x 4 lumber. Cut and assemble as shown below, including a center support. The overall length of the base should match the length given on the cage layout sheet.

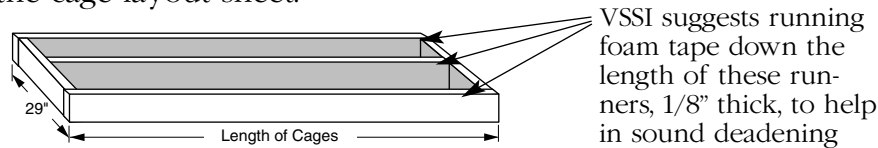

Concrete Construction: Concrete needs to be formed as shown below. Enough room should be allowed to leave a treated 2" x 4" on the front of the base (this provides a surface to screw into with wood screws when assembling the cages).

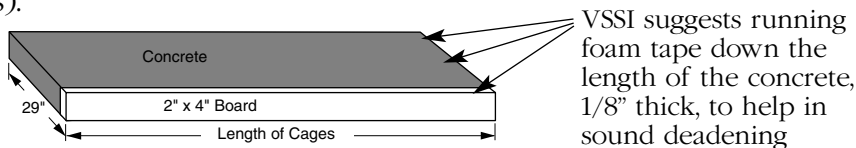

Assembly Cont'd

- Reinstall all door latches and hinges. Using #12 formed thread screws. **DO NOT TIGHTEN SCREWS**

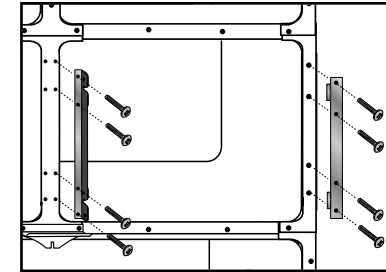

- After all trim strips, latches, hinges and slam latch plates have been installed, insert formed thread screws into all remaining open attachment points. (If optional top panel has been ordered, leave the top row of holes open for installation of this panel later in the assembly process).

- Use framing square and confirm that bank of cages is square. (you may need an extra person to help hold)

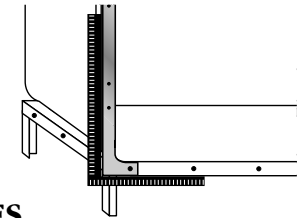

TIGHTEN ALL SCREWS EXCEPT DOOR LATCHES AND HINGE PLATES

If side panel option was ordered expose the adhesive on the foam tape that is installed on the panel and firmly press against cage side.

Optional Top Panel Installation (requires side panels)

Install top panel. Place formed thread screws through holes in top panel and tighten

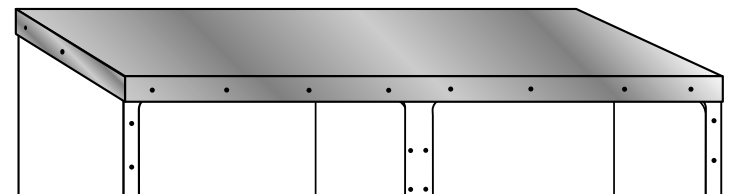

Assembly Cont'd

- Next, install side trim pieces on the upper cages, allow trim pieces from upper row to overlap trim piece of lower row.

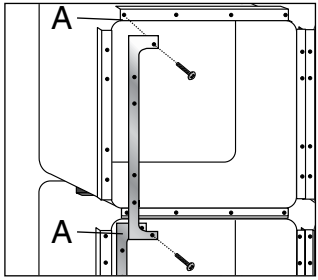

At this stage of assembly attach trim pieces at corners only (points A)

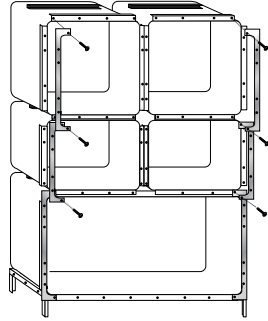

Note:
If optional side panels have been ordered, there will be no side trim strips to install

Optional side panel installation

- Working from the bottom up, install side panel as you would the side trim strip using 1/4-20 x 3/4" bolt, locking washer and hex nut to secure panel to the base frame. Use formed thread screws to secure the rest of the panel. **DO NOT EXPOSE THE ADHESIVE OF THE DOUBLE SIDED FOAM TAPE THAT IS INSTALLED ON YOUR SIDE PANEL AT THIS POINT.**

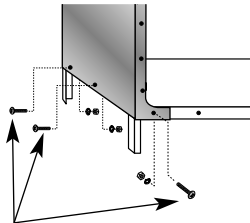

Note: if using a wooden base replace bolts, locking washers, and hex nuts **along the base with 3/4" wood screws (not provided)**

- Next, install center trim pieces using hardware as indicated below.

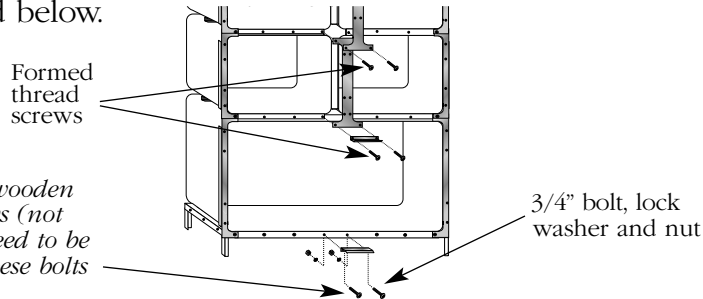

Note: If using a wooden base, wood screws (not included) will need to be substituted for these bolts

Assembly

- All cage bank are shipped with the doors, latches and hinges pre-installed. These must all be removed before assembly.

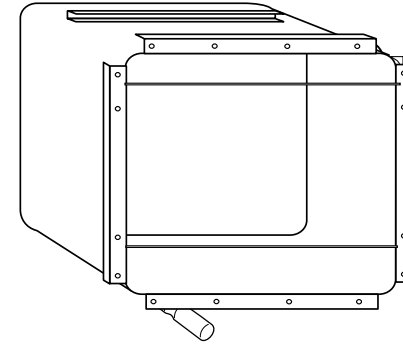

- Use level to ensure base is straight, checking front, back and sides. If using metal frame base feet can be adjusted to make it level.
- Position the first row of cages on the base (refer to the cage layout sheet for identification of the correct bank(s) for the first row. **You will not have to insert any screws or bolts until all cages are positioned and you are ready to install the trim pieces.**

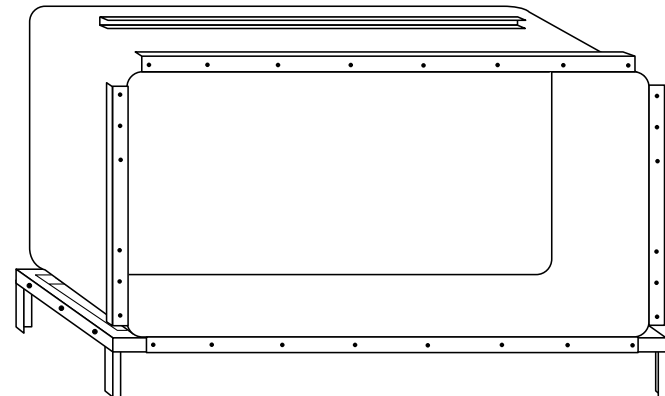

Assembly cont'd

- Place the next row of cages on top of the lower row of cages utilizing the pre-installed rear channels to interlock them in place. (see bottom of page for detail of locking channel)

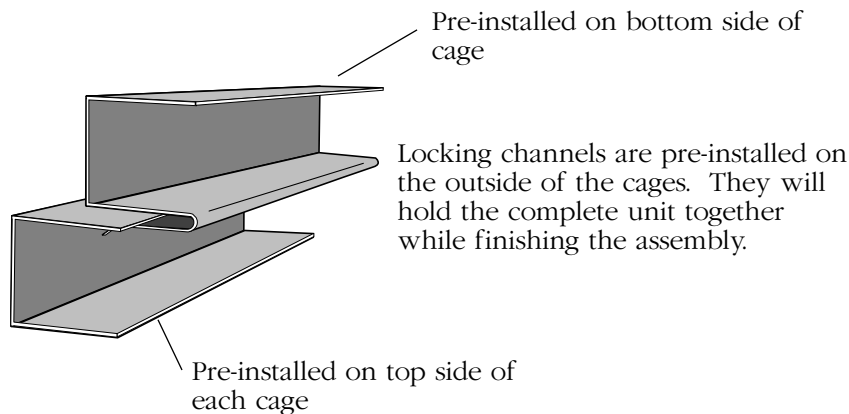
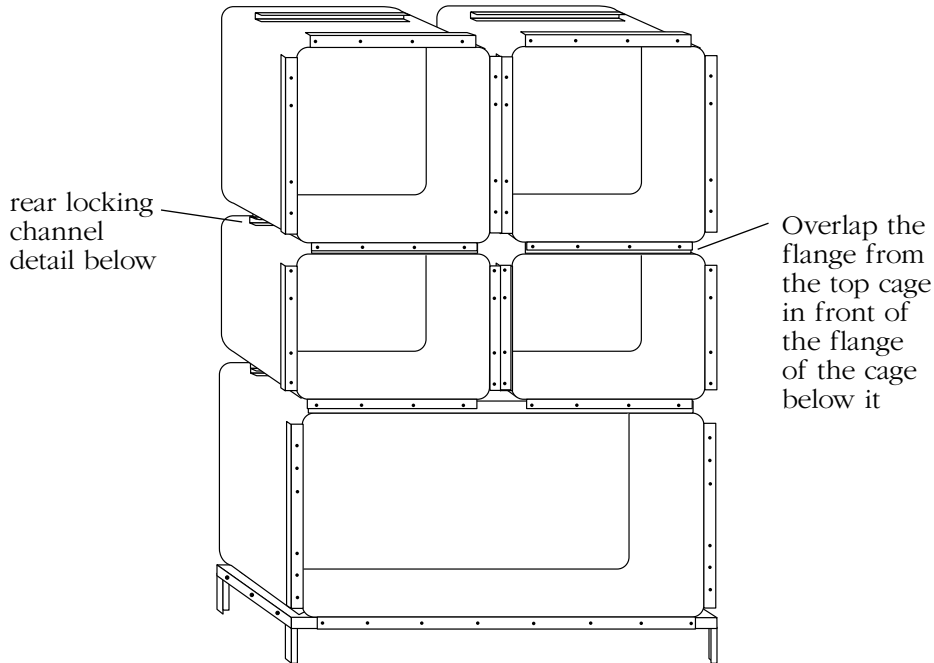

Assembly cont'd

NOTE: WHEN ASSEMBLING CAGES FOR THE FIRST TIME, ALWAYS **LEAVE NUTS, BOLTS AND SCREWS LOOSELY FITTED** SO ADJUSTMENTS CAN BE MADE. WHEN COMPLETELY ASSEMBLED, RETURN AND FIRMLY TIGHTEN.

- Once all cages are positioned and locked in place begin bolting the bottom cages to the base by inserting 1/4-20x3/4" bolts, locking washers and hex nuts provided. (it will be helpful to read ahead and note where trim pieces, hinges, and latches will be placed so you don't unnecessarily insert & remove bolts and screws before these items are reattached.

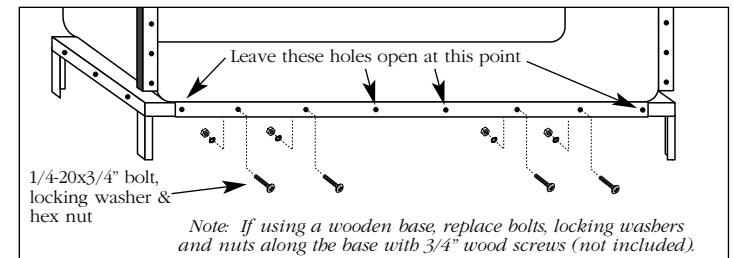

- After lower row of cages are secured to the base, install trim pieces on bottom cage bank using hardware as shown in the illustration below (again it will be helpful to note where other trim pieces, hinges and latches will go so you don't unnecessarily insert & remove bolts and screws before these items are reattached)

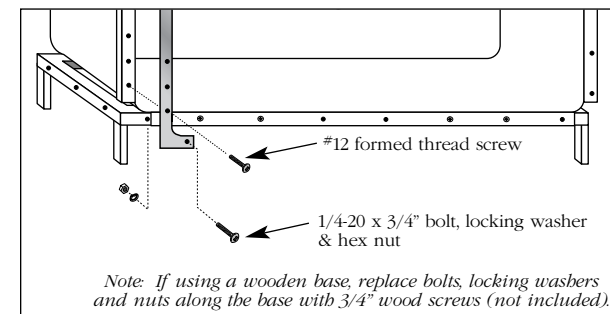

Note: If optional side panels have been ordered replace trim strip instructions with optional side panel instructions on page 8.